

# AVoptics

YOUR REQUIREMENTS, OUR CAPABILITY



# AVliteSplice<sup>TM</sup>

Inline Mechanical Splice

MAKING OPTICAL REPAIRS A REALITY

# AVliteSplice™

## Product Guide

### CONTENTS:

Part Description	03
Assembly Instructions / User Instruction	04
Tooling & Training	05



# AVliteSplice™

## Product Guide

AVliteSplice™ is a compact inline mechanical splice which can reinstate, repair or extend a fibre optic system.

Complete with minimal components and a non-intrusive design, thus enabling quick repairs which can be undertaken without the need to remove the cable or cable harness from operational platforms.



- ✓ Minimise downtime – enables in service repairs
- ✓ Quick and easy repair – can be performed in under 20 minutes
- ✓ Reduction of downtime associated costs - removes requirement to replace entire harness system
- ✓ Existing tooling and skillset optimised with the use of an AVLiteCure™ oven.
- ✓ Minimal components, lightweight and compact design Low optical loss solution
- ✓ Supports single and multimode applications
- ✓ Reinstates full mechanical integrity and high optical performance
- ✓ Can be repaired as a micro-connector
- ✓ High tensile pull force through torque load rather than less reliable spring loaded contact method
- ✓ Quick curing system through use of AVliteSplice™ oven

FIBRE TYPE	SINGLE MODE	MULTI MODE	
Insertion Loss	0.3 (typical)	0.1 (typical)	dB
Return Loss	> 55 (typical)	> 25 (typical)	dB
Length	50		mm
Diameter	5.5		mm
Weight	5.75		g
Pull force	111		N
Temperature Range	-55 to +150		°C

# Assembly Instructions / User Instructions

## AVliteSplice™ Optic Splice

The AVliteSplice™ optical splice is based on uniting two 1.25 mm diameter fibre optic termini in an easy and controlled manner. Termination is based on low-risk standard aerospace practice. It uses two aerospace standard termini torqued with a suitable mating force.

The termini are aligned via a central uniter which contains a ceramic alignment sleeve. Keying of the uniter and termini enables this design to be used for PC (Physical Contact) and APC (Angled Physical Contact) type terminations.

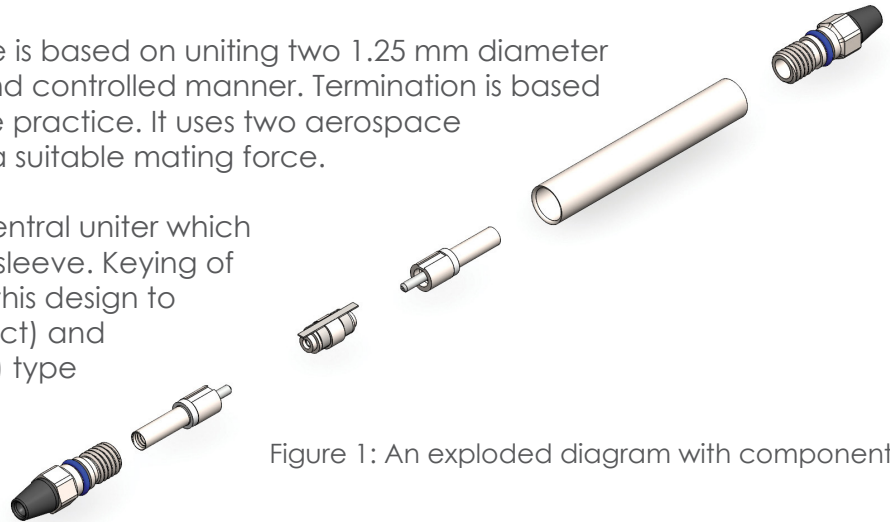

Figure 1: An exploded diagram with components

## Splice Termination Procedure

The splice uses an aerospace epoxy and polish termination process which is known to perform well in the aerospace environment.

- 1 Prepare cable ends for splicing



- 2 Terminate fibre using standard practices



- 3 Assemble both ends of splice



- 4 Assemble and torque splice to complete



# Tooling & Training

## AVliteSplice™ Optic Splice

The AVliteSplice™ can be assembled using existing aerospace termination tooling and practices. The following kits are available for terminating in situ on platform.

PART NUMBER	DESCRIPTION
-------------	-------------

ABFS-193-KIT-1xxx

Splice Termination Kit

- Cable Preparation
- AVliteCure™
- Polish
- Inspection



ABFS-193-KIT-2xxx

Test Kit

- Inspection
- Cleaning
- Testing



Training

AVoptics offers the following internationally recognised fibre optic training for the aerospace and other industries:

- ARINC 807 - Fundamentals Installer - Fabricator
- SAE - Installer - Fabricator
- Combined SAE/ARINC 807 Fabricator





## AVoptics Ltd

Address and registered office :  
7 Oak Way  
Lufton Trading Estate  
Yeovil  
Somerset  
BA22 8HS

(Registration No: 5654119)

+44 (0)1935 471606

✉ [info@AVoptics.com](mailto:info@AVoptics.com)

🌐 [www.AVoptics.com](http://www.AVoptics.com)